

図面／規格

(+)丸皿小ねじ

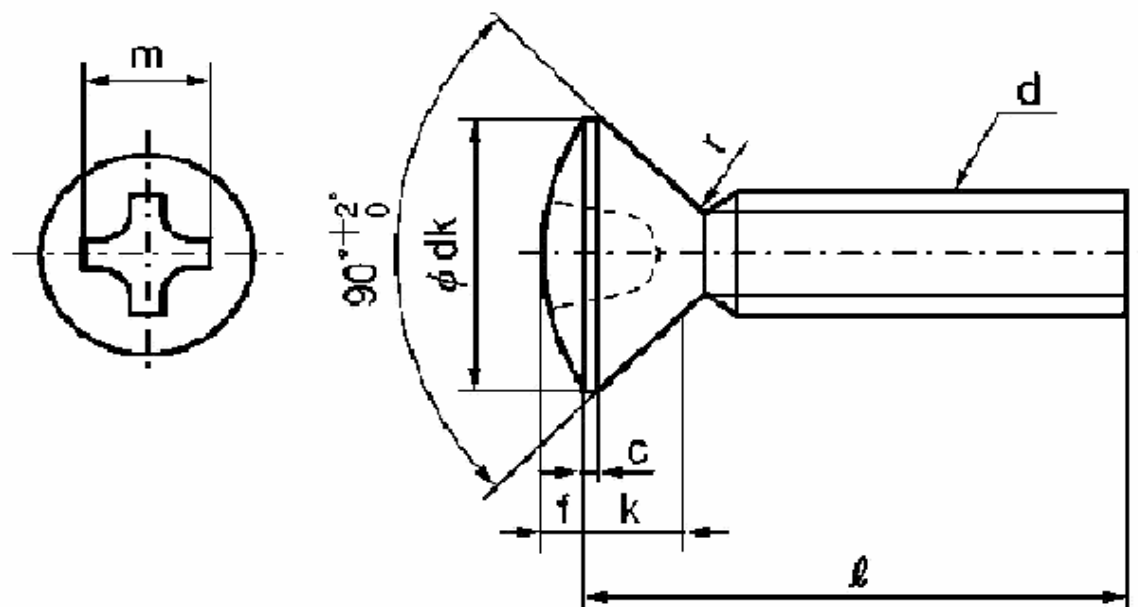

ねじの呼び	ピッチ	十字穴の番号	dk		k		c	f	k+f		m	q(十字穴深さ)		r
			基準寸法	許容差	基準寸法	許容差			基準寸法	許容差		参考	最大	
M2	0.4	1	4		1.2		0.2	0.4	1.6		2.4	1.21	0.85	0.20
M2.3	0.4		4.6	0	1.35	0	0.2	0.5	1.85	0	2.7	1.52	1.14	0.23
M2.5	0.45		5	-0.4	1.45	-0.2	0.2	0.55	2	-0.4	2.9	1.72	1.34	0.25
M2.6	0.45		5.2		1.5		0.2	0.6	2.1		2.9	1.72	1.34	0.26
M3	0.5	2	6	0	1.75		0.25	0.7	2.45		3.8	1.63	1.11	0.30
M3.5	0.6		7	-0.5	2	0	0.25	0.8	2.8	0	4.3	2.13	1.60	0.35
M4	0.7		8		2.3	-0.3	0.3	0.9	3.2	-0.5	4.7	2.53	1.99	0.40
M5	0.8		10	0	2.8		0.3	1.2	4		5.3	3.13	2.58	0.50
M6	1.0	3	12	0	3.4	0	0.4	1.4	4.8	0	6.9	3.46	2.90	0.60
M8	1.25		16	0	4.4	-0.4	0.4	1.8	6.2	-0.6	8.6	5.16	4.56	0.80